

# BJ Series

## Compact and built-in amplifier for long sensing distance

### Features

- Long sensing distance with high quality lens
- IP67 rated waterproof structure by rubber injection (IEC standard)
- Compact size : W20×H32×L10.6mm
- Detects up to 15m (Transmitted beam type)
- Light ON / Dark ON selectable
- Built-in sensitivity adjuster (Except for BJG30-DDT)
- Mutual interference prevention function (Diffuse reflective type)
- Stable detection for transparent object (LCD, PDP, glass etc) by BJG30-DDT.



**!** Please read "Caution for your safety" in operation manual before using.



### Specifications

Model	NPN Open collector output	BJ15M-TDT	BJ10M-TDT	BJ1M-DDT	BJ300-DDT	BJ100-DDT	BJG30-DDT
	PNP Open collector output	BJ15M-TDT-P	BJ10M-TDT-P	BJ1M-DDT-P	BJ300-DDT-P	BJ100-DDT-P	—
Sensing type	Transmitted beam			Diffuse reflective			
Sensing distance	0~15m	0~10m	0~1m	0~300mm	0~100mm	0~30mm	0~15mm
Sensing target	Opaque material over $\phi$ 12mm		Non-glossy white paper 300×300mm	Non-glossy white paper 100×100mm		Transparent glass 50×50mm (t=3.0mm)	
Hysteresis	—			Max. 20% at rated setting distance			
Response time	Max. 1ms						
Power supply	12~24VDC $\pm$ 10% (Ripple P-P: Max.10%)						
Current consumption	Emitter/Receiver : Max.20mA			Max.30mA			
Light source	Infrared LED (850nm)	Red LED (660nm)	Infrared LED (850nm)	Red LED (660nm)	Infrared LED (850nm)	Infrared LED (850nm)	
Sensitivity adjustment	Short rotator adjuster (210°)						—
Operation mode	Light ON/Dark ON selectable						Light ON mode fixed
Control output	NPN open collector output • Load voltage : Max. 26.4VDC • Load current : Max.100mA • Residual voltage : Max. 1V						
	PNP open collector output • Load voltage : Max. 26.4VDC • Load current : Max.100mA • Residual voltage : Min. (Power supply-2.5V)						—
Protection circuit	Reverse polarity protection, Output short-circuit protection		Reverse polarity protection, Interference prevention function, Output short-circuit protection				
Indicator	Operation : Red, Stable : Green (Emitter of power indicator for transmitted beam : Red)						
Connection	Outgoing cable type						
Insulation resistance	Max. 20M $\Omega$ (at 500VDC mega)						
Dielectric strength	1000VAC 50/60Hz for 1minute						
Vibration	1.5mm or 300mm amplitude at frequency of 10 ~ 55Hz in each of X, Y, Z directions for 2 hours						
Shock	500m/s <sup>2</sup> X, Y, Z directions for 3 times						
Ambient illumination	Sunlight : Max. 11,000lx, Incandescent lamp : Max. 3,000lx (Receiver illumination)						
Ambient temperature	-25 ~ 55°C (Storage : -40 ~ 70°C) at non-freezing status						
Ambient humidity	35 ~ 85%RH (at non-freezing status)						
Protection	IP67 (IEC standard)						
Material	Case : PC+ABS, Lens : PMMA, LED Cap : PC						
Cable	$\phi$ 3.5mm, 3P, Length:2m (Emitter of transmitted beam type : $\phi$ 3.5mm, 2P, Length:2m)						
Accessory	Fixing bracket, Bolt, Adjustment driver					Fixing bracket, Bolt	
Approval	<b>CE</b>						
Unit weight	Approx. 90g			Approx. 45g			

# Compact and built-in amplifier for long sensing distance

## Feature data

### Transmitted beam type

- BJ15M-TDT / BJ15M-TDT-P / BJ10M-TDT / BJ10M-TDT-P

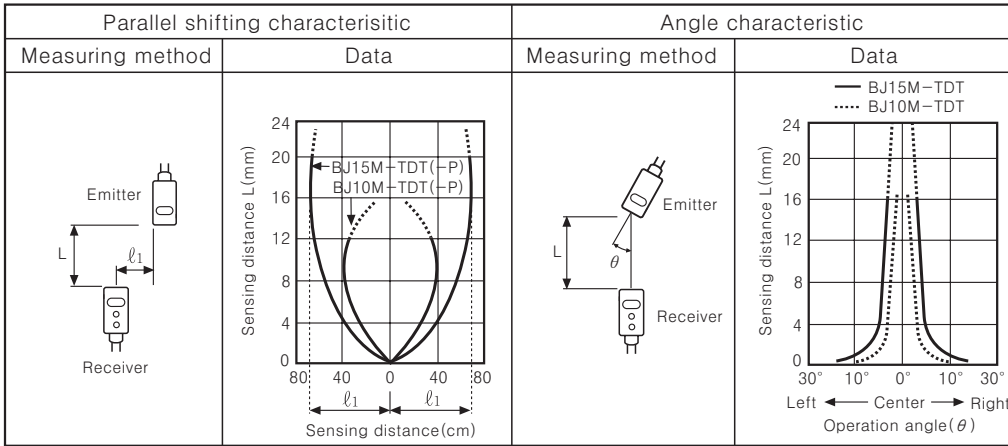

### Diffuse reflective

- BJ1M-DDT / BJ1M-DDT-P

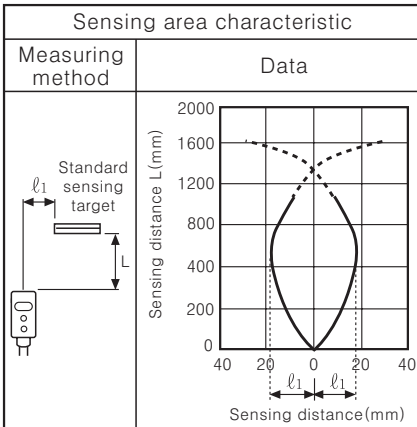

- BJ300-DDT / BJ300-DDT-P

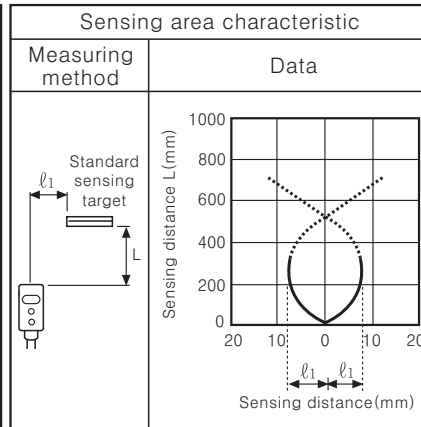

- BJ100-DDT / BJ100-DDT-P

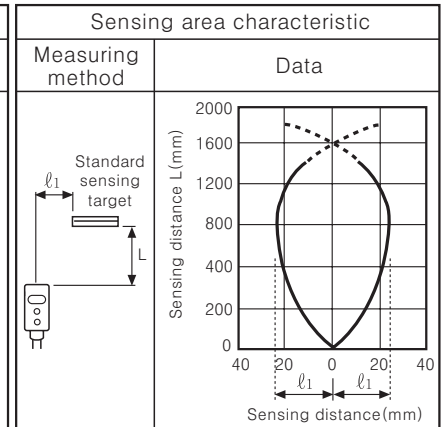

## Connections

### Transmitted beam

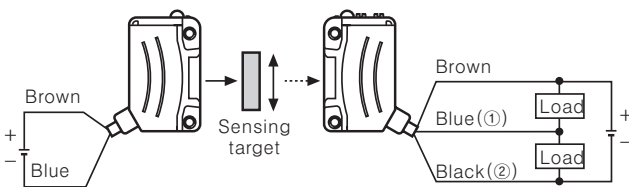

### Diffuse reflective

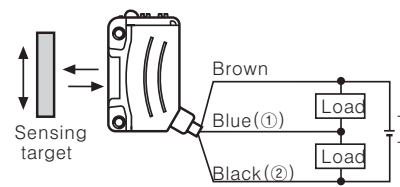

※ ① : The load connection of NPN open collector output, ② : The load connection of PNP open collector output

## Control output diagram

### NPN output

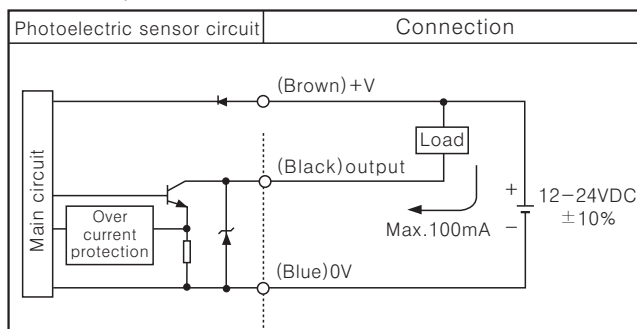

### PNP output

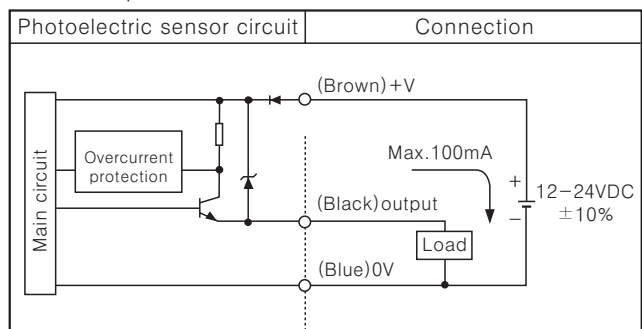

(A) Counter

(B) Timer

(C) Temp. controller

(D) Power controller

(E) Panel meter

(F) Tacho/Speed/Pulse meter

(G) Display unit

(H) Sensor controller

(I) Switching power supply

(J) Proximity sensor

(K) Photo electric sensor

(L) Pressure sensor

(M) Rotary encoder

(N) Stepping motor & Driver & Controller

(O) Graphic panel

(P) Production stoppage models & replacement

# BJ Series

## Operation mode

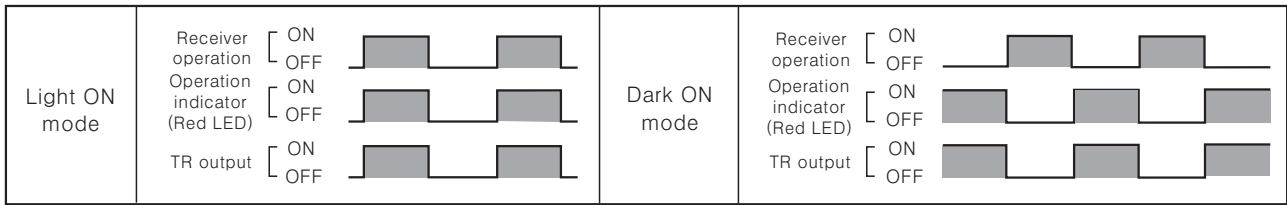

## Dimensions

(Unit:mm)

### Transmitted beam type

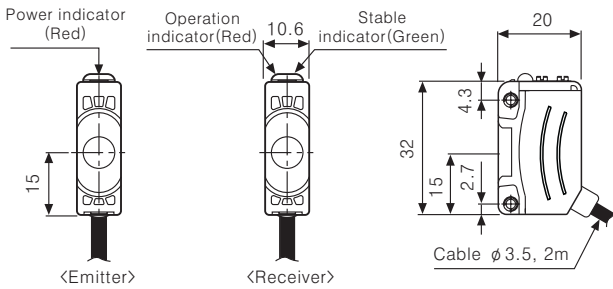

### Diffuse reflective type (Connect the bracket A)

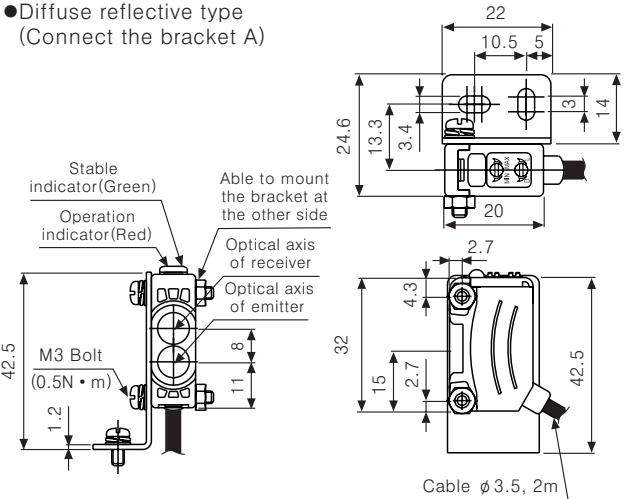

### Bracket A

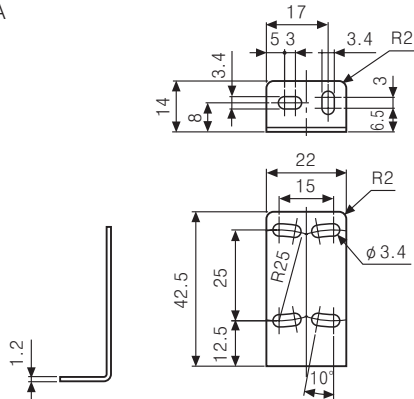

### Bracket B (Sold separately)

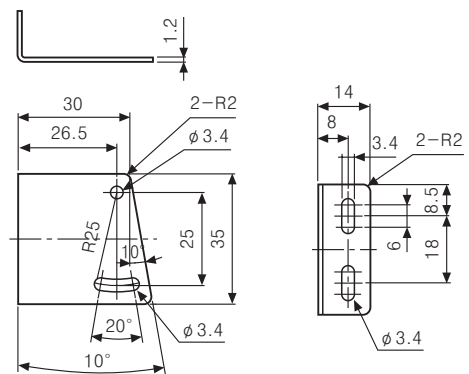

## Operation mode and Timing diagram

### Emitter

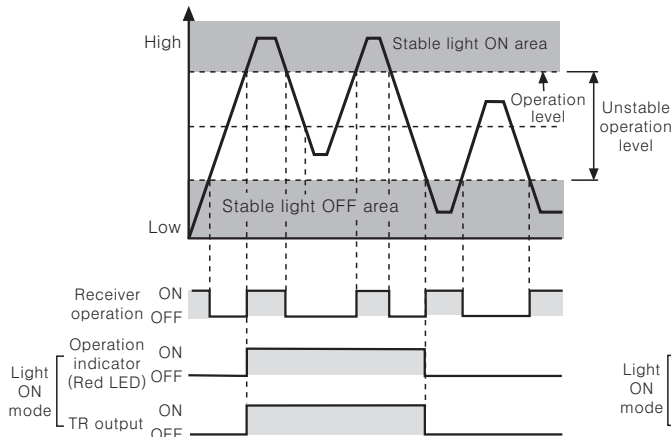

### Diffuse reflective

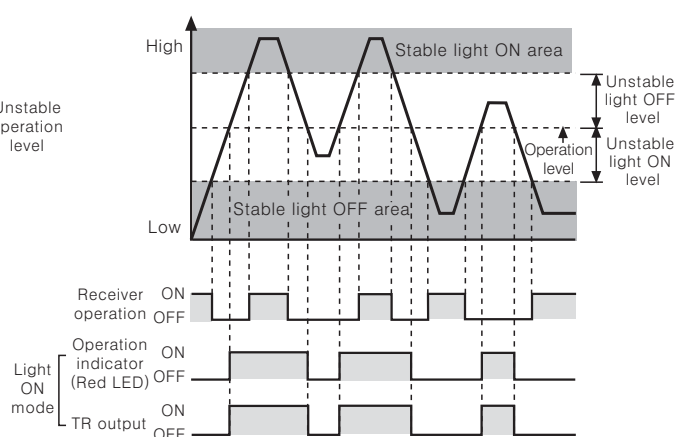



※ The waveform of 'Operation mode indicator' and 'TR output' is for Light ON mode, it is operated as reverse in Dark ON mode.

# Compact and built-in amplifier for long sensing distance

## ■ Mounting and sensitivity adjustment

### ◎ Switching of operation mode

Light ON mode (Light ON)		Turn the operation switching adjuster to right(L direction), it is set as Light ON mode.
Light OFF mode (Dark ON)		Turn the operation switching adjuster to left(D direction), it is set as Light OFF mode.

※ The operation switching adjuster is installed in the receiver for transmitted beam type.

### ◎ Mounting

#### ● Transmitted beam type

1. Place the emitter and receiver facing each other and apply the power.

2. After adjust the position of the emitter and receiver and check their stable indicating range, mount them in the middle of the range.

3. After mounting, check the operation of sensor and lighting of stable indicator in both status. (None or sensing target status)

※ When the sensing target is translucent or small (Under  $\phi 16\text{mm}$ ), it can be missed by the sensor because the light can penetrate it.

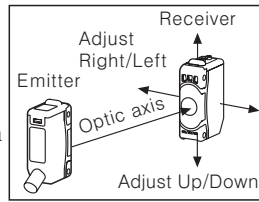

#### ● Diffuse reflective type

After place a sensing target, adjust the sensor to up • down, left • right. Then, fix the sensor in center of position where the indicator is operating.

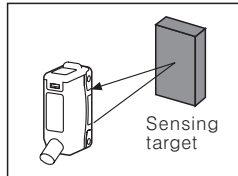

### ◎ Sensitivity adjustment

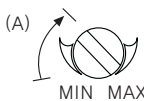
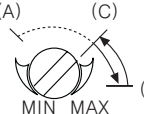
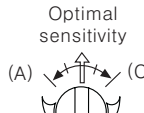
Order	Position	Description
1		Turn the sensitivity adjuster to the right of min. and check position(A) where the indicator is turned on in "Light ON status".
2		Turn the sensitivity adjuster more to the right of position(A), check position(B) where the indicator is turned on. And turn the adjuster to the left, check position(C) where the indicator is turned off in "Dark ON status". ※ If the indicator is not lighted although the adjuster is turned to the max. position, the max. position is(C).
3		Set the adjuster at the center of (A) and (C). To set the optimum sensitivity, check the operation and lighting of stable indicator with sensing target or without it. If the indicator is not lighted, please check the sensing method again because sensitivity is unstable.

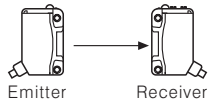
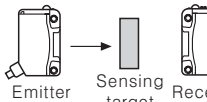
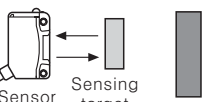
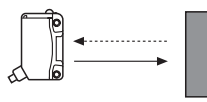
	"Light ON status"	"Light OFF status"
Transmitted beam type		
Diffuse effective		

※ Set the sensitivity to operate in a stable light ON area, the reliability for the environment (Temperature, voltage, dust etc) will be increased.

※ Do not apply an excessive force on adjuster, it can be broken.

- (A) Counter
- (B) Timer
- (C) Temp. controller
- (D) Power controller
- (E) Panel meter
- (F) Tacho/Speed/Pulse meter
- (G) Display unit
- (H) Sensor controller
- (I) Switching power supply
- (J) Proximity sensor
- (K) Photo electric sensor
- (L) Pressure sensor
- (M) Rotary encoder
- (N) Stepping motor & Driver & Controller
- (O) Graphic panel
- (P) Production stoppage models & replacement